

Energy Focus RedCap®

Item #: LEDFLT8-8xx-4xx-BBUF

Emergency Lighting System



WARNING:

Turn off power during installation. Detailed instructions are provided in this manual to prevent any risk of electrical shock or damage to product.



This manual provides information for the functionality and proper installation of the Energy Focus RedCap® Series Tubular LEDs (TLEDs). All servicing and installation of this product should be performed by qualified and authorized service personnel.

This retrofit kit is intended to be used with closed type (diffuser or lens/cover) or open type, 4ft. fluorescent luminaires.

WARNING – Risk of fire or electric shock.

Luminaire wiring and electrical parts may be damaged when drilling for installation of LED retrofit kit. Check for enclosed wiring and components. Only those open holes indicated in the photographs and/or drawings may be made or altered as a result of kit installation. Do not leave any other open holes in an enclosure of wiring or electrical components.

WARNING – Risk of fire or electric shock.

LED retrofit kit installation requires knowledge of luminaire electrical systems. If not qualified, do not attempt installation. Contact a qualified electrician.

WARNING – Risk of fire or electric shock.

Install this kit only in luminaires that have the construction features and dimensions shown in the photographs and/or drawings and where the input rating of the retrofit kit does not exceed the input rating of the luminaire.

WARNING – Risk of fire or electric shock.

To prevent wiring damage or abrasion, do not expose wiring to edges of sheet metal or other sharp objects.

WARNING:

RISK OF FIRE OR ELECTRIC SHOCK.

Please read all instructions and warnings thoroughly before beginning install.

This product shall be installed in accordance with the latest NEC and/or local authority having jurisdiction. Installation shall be performed by a qualified electrician understanding the construction and operation of this product and the electrical requirements involved.

Warranty

- Visit energyfocus.com for full standard warranty terms and conditions.
- Please note that the warranty may not be valid in case of improper installation (for example, not turning off main power before installation), damage due to normal wear and tear, exceptional operational conditions or unauthorized modifications.

FCC Verification

This device complies with Part 15 of the FCC Rules. Operation is subject to the following two conditions: (1) this device may not cause harmful interference, and (2) this device must accept any interference received, including interference that may cause undesired operation.

Safety

- READ AND FOLLOW ALL SAFETY INSTRUCTIONS.
- **ALWAYS DISCONNECT OR TERMINATE POWER TO LUMINAIRE PRIOR TO ANY INSTALLATION OR REPLACEMENT OF PRODUCT. Failure to do so may result in shock and/or severe injury or damage to product. Always test circuits before installation with voltage tester. Standard MAINS and EMERGENCY MAINS may be provided by separate circuits.**
- **This retrofit kit is accepted as a component of a luminaire where the suitability of the combination shall be determined by authorities having jurisdiction.**
- The RedCap® Lamp is intended for use in dry locations only. Do not use outdoors.
- Do not allow lampholder supply wires to touch hot surfaces. Do not mount the Redcap® Lamp near gas or electric heaters. Equipment should be mounted in locations and at heights where it will not readily be subjected to tampering by unauthorized personnel. Max mounting height: 13ft.
- Do not use this equipment for other than its intended use. The use of accessory equipment not recommended by Energy Focus may cause an unsafe condition.
- The standby power ratings as labeled on this equipment describes power consumption at the Emergency Input end in watts when battery is charged and is not intended to describe total or maximum power consumption. Install this equipment only where the total power consumption does not exceed the input rating of the retrofitted luminaire in accordance with the National Electrical Code, ANSI/NFPA 70.
- Bypass, remove, and properly dispose of fluorescent ballast and fluorescent battery backup ballast.
- Do not make modifications to or alter luminaire housing, ballast enclosure, or electrical components other than those required for proper installation.
- Only use the provided lampholders and rewire to line voltage. After re-wiring, the luminaire will no longer operate a fluorescent lamp.
- **Included luminaire warning label must be affixed to luminaire in a visible location after installation near the red lampholder.**
- The RedCap® Lamp will NOT operate with a dimmer switch.
- Lamp contains Nickel-Metal Hydride rechargeable batteries and must be recycled or disposed of properly in accordance with local requirements.
- SAVE THESE INSTRUCTIONS.

For questions:

Email: orders@energyfocus.com

Phone: 800.327.7877

Thank you for choosing Energy Focus!

This Package Includes:

- RedCap® LED lamp
- Luminaire warning label
- Installation Instructions
- Two (2) wired unshunted lamp holders

Product Overview

The RedCap® acts as both a normal lamp as well as emergency battery backup lamp for emergency egress lighting.

Direct Wire Mode: This product may be used as a direct-wire replacement of your current fluorescent tube. Rewiring your fixture, replacing lampholders and removal of ballast is required for this mode.

The “INPUT” end of the lamp, with white endcap, receives power from a standard MAINS power to operate the lamp in normal mode, typically controlled through a wall switch. The “EM INPUT” end of the lamp, with red endcap, is wired to “EMERGENCY MAINS,” power that is always on except during a power outage. The EM INPUT provides power to charge to the integrated battery. When power is present on the EM INPUT endcap, the lamp will act as a standard lamp. When emergency power is removed from the red endcap, the lamp will enter emergency mode, regardless of the state of the INPUT end.

RedCap® provides:

- Tubular LED Lamp with integrated driver designed to retrofit T8 fluorescent lighting.
- Custom high-temperature NiMH battery pack.
- Integrated battery charger.
- Universal Input Voltage of 120-277VAC (50/60 Hz).
- Isolated power and emergency power inputs.
- Integrated red indicator LED to show operating or error status.
- Automatic switch-over to emergency mode with 90-minute minimum emergency runtime.
- Three lamp color temperatures offered: 3500K, 4000K or 5000K.

In emergency mode, the RedCap® light output is designed as a 1-to-1 replacement for a legacy fluorescent lamp with emergency battery backup ballast.

For equivalence to fluorescent battery backup ballasts, one RedCap® Lamp would be comparable to a unit rated for 1400lm or less. If replacing a higher rated backup ballast, multiple RedCap® lamps may be required to achieve comparable brightness in egress lighting.

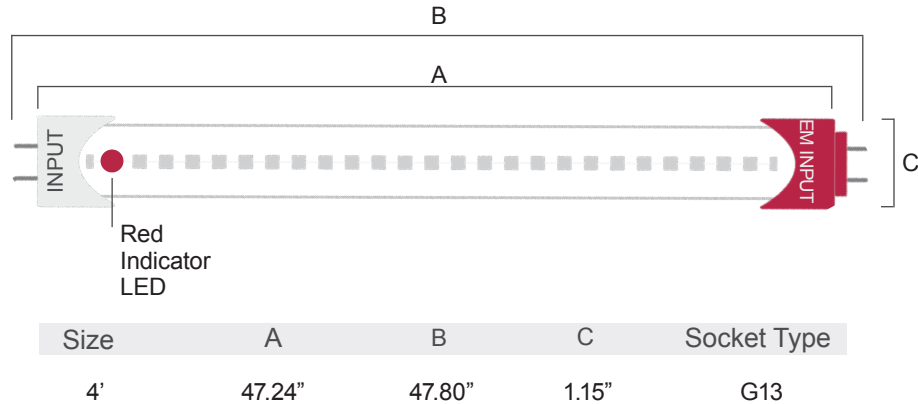

Figure 1: Lamp Dimensions

RedCap® Wiring and Retrofit Notes

- Divert Standard MAINS from the Fluorescent Emergency Ballast to the white “INPUT” end of the Redcap®.
- Divert the EMERGENCY MAINS power that only turns off during a power outage, from the Fluorescent Emergency Ballast to the red “EM INPUT” end of the RedCap®.
- Test switch: a normally-closed/momentary-open push button test switch is typically required for periodic testing.
 - Use of existing test switch is allowed and encouraged.
 - Test switch may be located in or near luminaire or remotely for easy access.
 - Test switch will interrupt power to the EM INPUT as indicated in figure 1. The RedCap® will enter emergency mode regardless of the status of power on the INPUT end. Note that other lamps may not shut off during this test.
- RedCap® may be powered from one circuit or circuits from separate phases without issue, as internal circuitry is properly isolated.

RedCap® Installation Instructions

1. Turn off the power to the light luminaire at the breaker panel. This includes both Standard MAINS and Emergency MAINS, which may be on a separate circuit. Ensure all circuits are de-energized before proceeding by testing with a voltage detector.
2. Remove existing fluorescent lamps. Dispose of or recycle these items properly in accordance with local requirements as they contain mercury vapor which is a hazardous material.
3. Open the wiring cover or remove the reflector to expose the fluorescent ballast(s). Remove all ballasts and lampholders. Dispose or recycle in accordance with local requirements.
4. Install the lampholders provided with the Redcap® retrofit kit into the luminaire.
5. Before reinstalling the wiring cover or reflector, check that the wires are positioned away from screws or sharp edges, to prevent damage to the insulation.
6. **IMPORTANT:** Move the provided battery connection jumper from the shipping position to recessed pins on the red endcap. The lamp will light up.

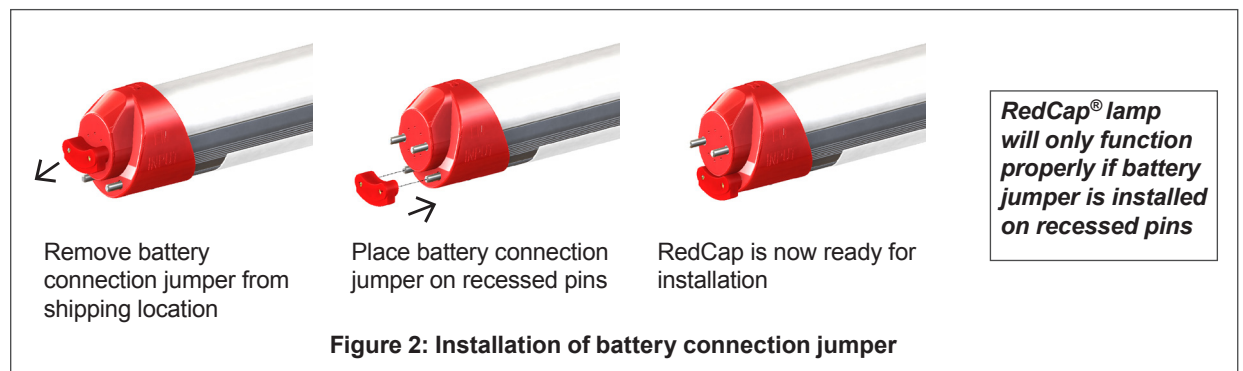

7. Install the LED lamp in the lampholders. The lamp will have to be rotated to provide power and should audibly click into place upon rotation.
8. **IMPORTANT:** After the LED Lamps are installed, affix the luminaire warning label inside the luminaire in an easily visible location near the red lampholder.
9. Close the diffuser or louver and restore the Standard MAINS and EMERGENCY MAINS power at the breaker and turn the light on with the wall switch.

Typical Fluorescent Emergency Ballast Wiring Diagram

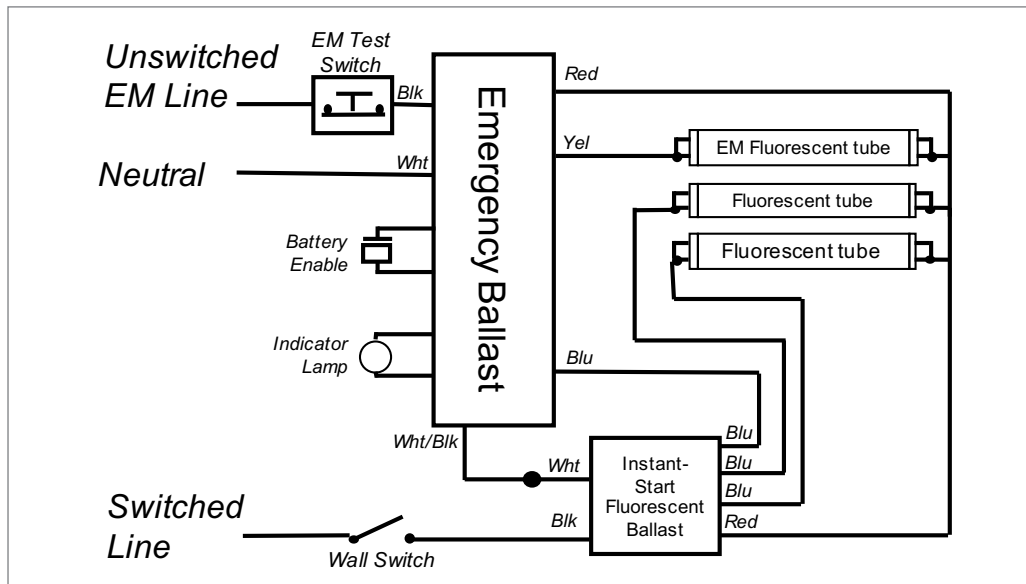

RedCap® Emergency Lamp Wiring Diagram Single-Ended Power

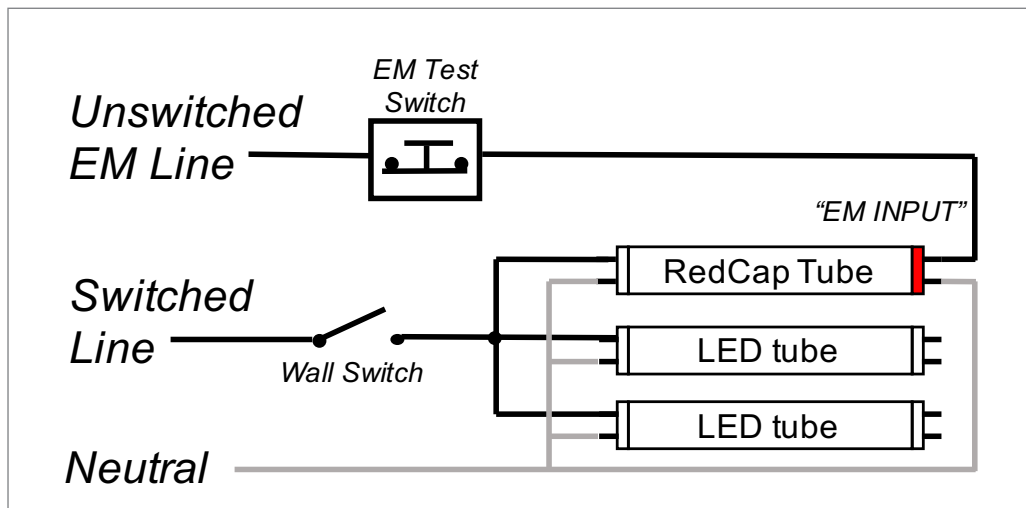
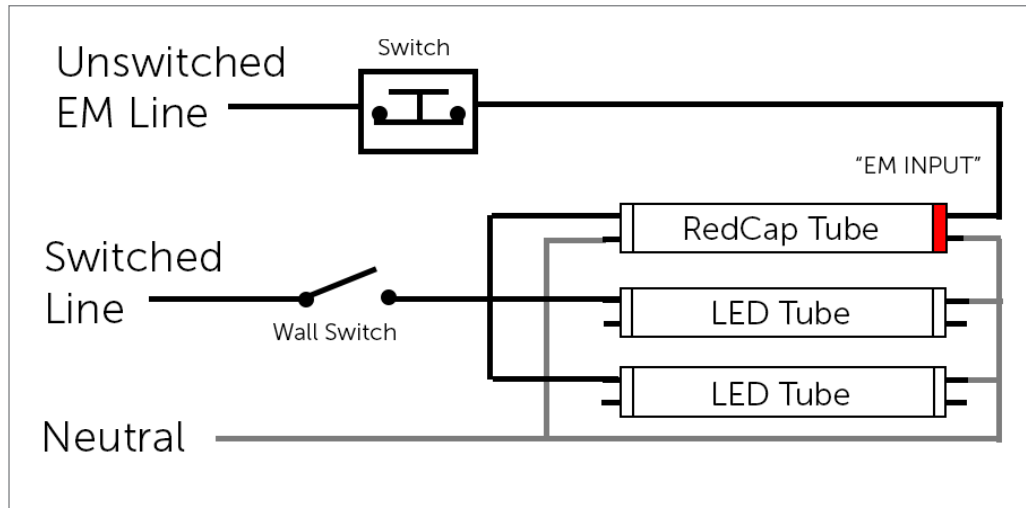

Figure 3: Wiring Diagrams

RedCap® Emergency Lamp Wiring Diagram Double-Ended Power



Post-Installation Verification Testing

1. Observe that the lamp turns on and off normally with the wall switch. If the lamp enters emergency mode with wall-switch in the off position, it may be inserted backwards in the luminaire or lampholders may not be wired properly.
2. Ensure that the Red Indicator LED blinks briefly once every 15 seconds. If red indicator does not blink, check luminaire wiring to ensure red lampholder is receiving power. If indicator is blinking rapidly, check that the battery jumper was properly installed. See step 6 of installation instruction above.
3. To test the emergency mode, push and hold the test switch or turn off emergency power at the breaker to simulate a power outage. The lamp will turn off and automatically enter emergency mode within seconds and the Red Indicator LED will stay off. The lamp may fail to illuminate if batteries are depleted. Allow 24 hours to charge and repeat the test.

Periodic Emergency Function Testing

Consult local fire marshal or electrical code authority for requirements on periodic testing, or NFPA 70 (National Electric Code) or NFPA 101 (Life Safety Code) for details.

Red Indicator LED Function

- **OFF:** No power to red endcap. Check power to EM INPUT (red endcap).
- **SHORT INTERMITTENT BLINK (15 second interval):** Normal operation, armed/charging.
- **RAPID BLINK:** Battery error or internal error. Follow the procedure below to determine if battery is not detected or not charging.
 1. Turn off both AC and EM power at the breaker.
 2. Remove lamp from the luminaire.
 3. Remove and reinstall battery jumper as shown in Figure 5.
 4. Re-install lamp into luminaire and restore power to luminaire.

If the error is persistent, contact Energy Focus for technical support at 1-800 327-7877

